

The CW Trainer

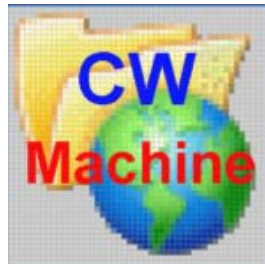

Contents

Introduction	3
Copying and Sending Morse Code	4
Morse Timing and Speed.....	5
Advanced Farnsworth Timing.....	6
Where is the Power Switch?	7
Serial Communication.....	7
Loading the Firmware	8
The Menu System.....	9
Adjusting the LCD Contrast	10
Decoding your Transmission	11
Getting Started.....	12
Adjustments Using the Menu System	13
Adjusting the Character Space.....	13
Adjusting the Word Space.....	13
Adjusting the Morse Speed Range.....	14
Using AUTOplus to Automatically Increment the Morse Speed	15
The DASHplus Feature	16
Setting the Key Type	16
Toggling the Auto Word Space Feature (AUTOWS)	17
Changing Volume and Pitch of the Sidetone (SOUND).....	17
Switching Keying On or Off (KEYING)	18
Switching the Tone On or Off (TONE).....	18
Setting the Key Orientation (REVRSE)	18
Setting the Serial Communication Speed.....	19
Loading a Message File	19
Resetting the Keyer.....	20
Using the CW Trainer	21
The Message File.....	21
National Language Characters.....	22
Operational Prosigns.....	23
- =	23
- >	23
- +	23
- (.....	23
- %	23
- #	23
- ^	23
- &	23
Keypad Functions	24
Switching Keying and Tone On or Off [NumLock, Esc]	24
Changing the Lesson [/] or <do> Pseudo Prosign	24
Starting a Message [0 ... 9].....	25
Interrupting and Resuming a Message [Enter].....	25
Resetting the Timer [.].....	25

Delayed Message Action [+] or <dm> Pseudo Prosign	25
Backing Off by One Word [-].....	26
Flash Card Mode [*]	26
Appendix A: Error Codes	27
Appendix B: The Menu Structure	28

Introduction

The **CW Trainer** is firmware designed exclusively for the **CW Machine Hardware** platform. It is a CW memory keyer with functions that make it particularly suited for training purposes.

Some features of this keyer are:

- Calibrated speed range from 5wpm to 75wpm
- Iambic A / B mode keying, emulation of a mechanical bug, and support for straight keys
- Decoder for text created with your paddle or straight key
- Adjustable character and word spacing for advanced Farnsworth timing
- Automatic speed increase over time (selectable option)
- Real time stop watch to time the duration of messages
- Delayed start and restart of messages to let you grab pencil and paper
- Flash card mode to let you practice copying complete words in your head
- Up to 100 variable length messages organized into 10 lessons of 10 messages each. The combined total of all messages is in excess of 540,000 characters, or about 75 hours of non-stop CW at 20 wpm.

All settings and messages are kept in non-volatile memory and will be retained even if power, including the backup battery, is completely removed.

The selection of various features and functions is accomplished in an intuitive way with a joystick and through messages and values displayed on the LCD display of the CW Machine Hardware.

CW characters can be created manually using a dual lever paddle or a straight key. The CW Trainer supports iambic modes A or B, or it can emulate a mechanical bug with manual creation of dashes.

In addition to a paddle a numeric keypad or a standard 101-key PC keyboard are required. It is used to select, and to start and stop messages, and to invoke some other features as explained further below.

Copying and Sending Morse Code

If you are new to Morse code, you may be tempted to focus on copying signals, and the CW Trainer offers you a great variety of techniques to help you increase your copying speed. But actually the abilities to copy and to send Morse code are closely related, and you should spend about as much time sending as you spend copying. As you grow older, your hand-ear coordination often deteriorates, and old timers can often copy much faster than they can send. But if you start as a younger person you may actually find that the maximum speed that you can send at also defines the limit of your ability to copy – improve your sending speed, and your ability to copy will improve correspondingly.

The CW Trainer lets you hone your sending skills by showing you the characters that you are sending right away on the LCD display. Initially speed is not important. Try to get the timing right to send perfect Morse – speed will take care of itself later.

Unless you come from ingrained habits with mechanical bugs, and maybe even then, you should attempt to use “squeeze” mode with your paddles. Moving your finger tips away from the finger pieces of your paddle is inefficient and unnecessary. High speed operators who grew up with iambic keyers hardly move their hand while they are sending, allowing them to use minimal return force and contact spacing on their paddle and not waste time wiggling their fingers or waving their hand.

Squeeze mode is easy if you start slow. You just have to remember that squeezing the paddles creates an alternating string of dots and dashes, starting with the contact side that you close first. And, equally important, that you can insert a dot into a string of dashes without releasing the dash side, and a dash into a string of dots without releasing the dot side. Thus, a character like C is a single squeeze operation where you close the dash side just a fraction of a second before the dot side; and a character like Q is just a string of dashes where you briefly tap the dot side at some time during the second dash without ever releasing the dash side. Go through the characters one by one as you learn them and, using “squeeze” mode and automatic dash/dot insertion, find out how you can produce them with the minimum amount of finger movement.

The difference between iambic A and B modes comes into play when you squeeze the paddle and let both sides go simultaneously at the end of a character. Iambic B will add an additional trailing element in some instances where iambic A does not, and it usually feels more tolerant if you make minute timing mistakes. If you are starting fresh, try iambic B.

Morse Timing and Speed

The CW Trainer, as the name implies, is primarily designed as a training device, although it can be used as a “regular” memory keyer with a large number of potentially very long messages – up to 100 messages with a combined length exceeding 540,000 characters; certainly much more that required for all practical purposes as a memory keyer.

If you are using the CW Trainer to learn Morse code or to improve your speed, it is important to understand the concept of “speed” and the adjustments that are available in the CW Trainer.

Morse code consists of short and long **elements** separated by an **elementary space**. Elements and elementary spaces are strung together to form **characters** separated by **character spaces**. Characters and character spaces are strung together to form **words** separated by **word spaces**. There is a precise definition of the timing relationships between all of these, and only signals that conform to these timing specifications are truly Morse code – everything else that deviates from these specifications may sound like Morse, but it really isn’t from a purist’s point of view. For training purposes some of these timing relationships are often adjusted, and the CW Trainer allows you to do so, but at the end of the day you should strive to come as close as possible to the theoretical ideal, and the often heard argument that some other timing characteristics “sound better” is just a euphemism for a signal that “kinda sounds like Morse” when it really isn’t.

The time is measured in an elementary unit that we will call **tick** here (this is not a standard term). So this is the precise definition of Morse code:

- A **dot** is a sound of one tick in duration, followed by a silence of one tick.
- A **dash** is a sound of three ticks in duration, followed by a silence of one tick
- A **character space** is an additional silence of two ticks after the preceding dash or dot. Since the dash or dot already ends with one tick of silence, as defined above, the silence between the sounds of two successive characters is three ticks in duration.
- A **word space** is an additional silence of four ticks in duration after the preceding character. Since a character already ends with three ticks of silence, as defined above, the silence between the sounds of two successive words is seven ticks in duration.

Morse speed is often measured in **words per minute (wpm)**. The accepted standard is that a “word” has a length of 50 ticks, including the trailing word space. If you add the duration of the letters, the character spaces, and the trailing word space as defined above, you will see that the word **PARIS** takes 50 ticks, and it is often used as the “standard” word for calibration purposes.

Advanced Farnsworth Timing

For training purposes most methods use an approach where a character is sent at a higher speed, followed by a longer silence; this is called **Farnsworth** timing. It helps avoid the tendency of many beginners to count the dots and dashes in a character and lets you hear the character as one aural pattern. Once you progress to higher speeds you will actually hear many words as one aural pattern – just like in written text where you normally will not dissect a word into single letters while you are reading. The CW Trainer helps you practice this skill by letting you increase just the word spacing, keeping words together at higher speed, or by using flash card mode to practice copying in your head.

When Farnsworth timing is used, there is obviously a difference between the character speed and the word speed. The word PARIS takes 50 ticks with standard timing, but if you increase the character space from 2 to 4, and the word space from 4 to 8, effectively doubling the standard definition given above, PARIS would have a length of 64 ticks, and you could send it only $50/64 = 0.78$ times as often in a minute. The CW Trainer takes this into account and displays the speed as, e.g., 15C10W, meaning that the characters are sent at a speed corresponding to 15wpm, and Farnsworth timing slows the word speed down to 10wpm. The CW Trainer will not allow you to reduce the character space below the defined standard of 2, which would be very poor practice, and it makes sure that the word space is at least 2 ticks longer than the character space. In practice you will often hear shorter word spaces, but this is a questionable habit and should not be encouraged. All this means that in the CW Trainer the word speed can never exceed the character speed and, if Farnsworth timing is used, it will be less than the character speed.

The speed potentiometer on the CW Machine Hardware is used to adjust the speed, and it is calculated and displayed many times per second in the 15C10W format explained above, taking into account the Farnsworth spacing and some other settings of the CW Trainer. The CW Trainer has an option that will automatically increase the speed over time as a message is being sent, and the display will always show the actual speed.

If you are creating Morse code with your paddle or straight key, the decoder function of the CW Trainer allows some deviation from perfect timing and will still recognize what you are sending.

Where is the Power Switch?

That's an easy one: The CW Machine device does not have a dedicated power switch. It is usually powered by an external power supply that can deliver 150mA or more at 9-15V DC, or through a pin on the serial port as described in the hardware documentation. It also has a CR2030 lithium knob cell which lets you invoke all menu functions and even communicate via the serial port with only that knob cell. All other functions, however, will not work when it is powered only by the knob cell.

In normal operation the CW Machine draws less than 20mA. The lowest current drain is achieved when you push the Reset button and the LCD screen goes blank; in this state the current drain, although not zero, is below 10mA.

When you first connect a power supply or a battery, the LCD display will be blank. **You start the firmware application by touching the left side of your paddle (or by moving the joystick up).**

Serial Communication

If your PC does not have a serial port, you can use a high-quality **USB-serial adapter**. It should be mapped to **COM1 ... COM4**. Many inexpensive adapters have proven problematic, and the only types that have worked consistently at full speed without problems are the adapter that we are offering and adapters made by Keyspan, e.g. the **Keyspan USA-19HS**.

The serial connector on the CW Machine Hardware is used for two purposes:

- It lets you load firmware into the keyer. This is typically done using the boot loader that comes with the AVR Butterfly board and the ATprog program for Windows. (similar programs are available for other PC operating systems) This function automatically adjusts the settings of the serial port and the settings described below are not relevant for it.
- It lets the firmware exchange data with programs running on a PC. A typical example is the message file that you can load into the CW Trainer.

All of our firmware programs will support communication with a terminal program on a PC, although more convenient Windows programs may be available to complement the functions of a particular firmware. A typical example is our **CW Trainer Manager** program, which simplifies and extends the operation of the CW Trainer if you are running a Windows PC; if you are using it you don't have to concern yourself with the communication settings.

If you are using a terminal program, however, it has to understand XON/XOFF flow control, and it has to support one of the communication speeds that you can select in the firmware. The speed is normally set to 38,400 baud.

You have to set the communication parameters in your terminal program as follows:

- 8 data bits, no parity, 1 stop bit
- XON/XOFF flow control
- Uncheck (disable) these options in the ASCII Sending section:
 - *Send line ends with line feeds*
 - *Echo characters locally*
- Set the line delay and the character delay both to 0 milliseconds
- Make sure to set the ASCII Receiving parameters to:
 - *Enable Append line feeds to incoming line ends (check the box)*
 - *Disable Force incoming 7-bit ASCII (uncheck the box)*
 - *Enable Wrap lines that exceed terminal width (check the box)*

Loading the Firmware

The CW Machine Hardware comes loaded with the firmware for the CW Machine keyer. So, before using the CW Trainer you have to load the CW Trainer firmware into the device. It is contained in a file called **KeyTrain.hex**, and the procedure to load it is described in the documentation for the CW Machine Hardware. If you are using the CW Machine Manager for Windows, you can use the Software screen of that program to load the KeyTrain.hex file, and the update procedure will automatically start the ***CW Trainer Manager*** for Windows.

The communication settings described above are not relevant for this process. **However, the port has to be COM1 ... COM4. The AVRprog program that is used to update the firmware will not work with ports above COM4.**

When you first connect a power supply or a battery, the LCD display will be blank. **To start the firmware application, touch the left side of your paddle (or move the joystick up).**

The Menu System

You navigate the menus of the CW Trainer by moving the joystick in one of five directions, left, right, away from you (called *up*), towards you (called *down*), or pressing it down like a button (called *push*).

The CW Trainer has two basic modes called ***adjustment mode*** and ***operational mode***. In adjustment mode you make the various settings that establish the operational characteristics of the keyer, but you cannot create Morse signals. In operational mode you can create Morse signals and display certain information, but you cannot change settings.

When it is first switched on, or after a reset, the keyer starts in operational mode as a iambic Mode B keyer with transmitter keying turned off – so you could start using it for keying practice right away. But you should probably first switch to adjustment mode to familiarize yourself with the many features and functions.

The menu system of the keyer is organized into several rows and columns. Items in one row form a group of related functions – e.g. there is a row that contains all the option selections of the keyer.

One of the rows, the one that displays the timer, speed, and decoder, will be referred to as the ***Home row*** in this documentation. The last display mode that you select in the Home row will be remembered, and when you return from adjustment mode back to the Home row, the keyer will resume with that display mode.

One of the columns, the one that shows Option, Load, etc., is referred to as the ***Home column*** in this documentation.

The menu choices in operational mode form a single row. In operational mode the up and down joystick movements act like a Morse paddle. Moving the joystick up is equivalent to pressing the left paddle of a key, and moving the joystick down is equivalent to pressing the right paddle of a key – so, if you rotate the keyer by 90 degrees you could use the joystick as a paddle in an emergency situation.

In *operational mode* you can switch to *adjustment mode* by pushing the joystick down for more than 0.25 seconds until you hear a beep. **Operational mode is indicated by a down-arrow in the fifth position of the display** – so you should push the joystick and see the arrow disappear.

You can switch back *from adjustment mode to operational mode* in several ways:

- Push the joystick on the option or speed displays
- Press the left paddle of your key for about 0.5 seconds
- Move the joystick up and hold it for about 0.5 seconds
- Push any key on the numeric keypad or keyboard

You'll find a pictorial description of the whole menu system in the Appendix B.

If you are using the **CW Trainer Manager** program for Windows, all of the adjustment functions that are described in the following chapters are conveniently handled from Windows screens, and you will rarely have to touch the keyer itself.

Adjusting the LCD Contrast

The LCD contrast is set to the maximum after a device reset or when the CW Machine is started for the first time. If you are viewing the display from an oblique angle, it may be clearer if you adjust the contrast to a lower value.

In operational mode, pushing in the joystick (like a button) briefly for less than 0.25 seconds cycles through the 16 possible settings for the LCD contrast with each push. (If you push for too long, the keyer will beep and enter adjustment mode, as described above.) The new **contrast value is persistent** – pushing the hardware Reset button or removing the power supply will not change the last contrast setting. A reset of the firmware, however, as explained in “Resetting the Keyer”, will restore the LCD contrast to the maximum value.

Decoding your Transmission

The CW Trainer shows the characters that you are creating with a paddle or a straight key as a “ticker tape” on the LCD display, and simultaneously in the monitor window of the CW Trainer Manager. (The decoder view is one of the choices in the home row of the menu, as explained further down.)

The decoder logic that transforms the dits and dahs made with a dual-lever paddle into characters uses an algorithm that allows slight deviations from perfect timing. The specification of Morse code defines the space between elements within a character as 1 bit (= the length of a dit). The keyer logic will allow you to use up to 1.5 bits; this makes it easier to keep a character “together” at higher speeds. The standard space between words is defined as 7 bits, but many operators use a shorter word space, especially at slower speeds. Therefore the decoder algorithm accepts any pause of at least 5 bits as a word space.

If you are using a **straight key in HAND** mode, you still have to use the speed potentiometer to let the decoder logic know the approximate speed that you will be sending at. The decoder logic uses the setting of the speed potentiometer to distinguish between dits and dahs, and to decide whether a word space or character space should be inserted. Your actual transmission speed can vary significantly from the speed potentiometer setting, and your character formation can be quite “individual”, but if it deviates too much from the standard, you are going to see “garbage”. Just experiment a bit with the speed potentiometer until you see that your signal is properly decoded.

Getting Started

When it is first switched on, the CW Trainer starts with a scrolling version display. If you move the joystick or tap your paddle it switches to operational mode showing the timer. **(If you push the joystick down for more than 0.5 sec while the version is being displayed it will perform a reset to recover from a corrupted EEPROM.)** Operational mode is indicated by a down-arrow in the fifth character position of the display. You should also hook up a numeric keypad or a keyboard. **It usually is not a good idea to “hot plug” the keyboard or keypad – so remove the power before plugging it in.** If the keypad does not respond, move the joystick to reset it. Move and hold the joystick up, and you should hear a string of dots from the speaker, move and hold the joystick down, and you should hear a string of dashes.

Since the CW Trainer is primarily designed as a training device, the keying output to your transmitter is initially disabled, and the keyer will create a side tone. If you want to use it as a “real” keyer connected to a transmitter, you will have to enable the keying function, and you probably want to disable the tone. This is done through functions in the menu that are described further down, and the keyer will “remember” these settings even if you remove the power including all batteries. To temporarily toggle transmitter keying on and the tone off (and vice versa), you can also press the NumLock key on the numeric keypad – this setting will not be “remembered”, however, if power is removed. Whenever the transmitter keying function is enabled, you’ll see an up-arrow in position 2 of the LCD display, and another up-arrow in position 1 will flicker in sync with any Morse signal you are sending.

In operational mode you can cycle through various display options by moving the joystick left or right, but you cannot change a setting. The keyer will remember your last display selection for operational mode and return to it if you switch power off and back on. The navigation and the display options are detailed in Appendix B. The Decoder display shows characters and words that are being sent, either from a recorded message or created with your paddle or straight key, as a scrolling “ticker tape” on the LCD display and simultaneously in the monitor window of the CW Trainer Manager program. **So the CW Trainer not only lets you practice copying Morse code, but it will also help you improve your “fist” by decoding what you are sending.**

If you have already hooked up a paddle, see that it produces dots and dashes. Depending on how you wired it, it may be reversed from what you expected – but there is a menu function to reverse the paddle orientation.

Now, push the joystick for about 0.5 seconds to get to adjustment mode and see that there is no down-arrow in position 5 of the LCD display.

Adjustments Using the Menu System

Adjusting the Character Space

The CW Trainer lets you use characters with a larger than regular character space for training purposes. The standard timing is explained in the “Morse Timing and Speed” chapter above. In this keyer the incremental word space and character space can be adjusted separately, however there are some dependencies between both values. The character space has a minimum of 2 ticks and a maximum of 97 ticks. As you increase the character space, the word space will also be increased to twice the character space, unless it already exceeds that value, until its maximum of 99 is reached.

Make sure you are in adjustment mode (no down arrow in position 5). Move the joystick up or down in the Home column until you see the speed row. Move the joystick left to get the **CSP** (Character Space) display, initially CSP 2. You can increase this value by moving the joystick up, and you can decrease it by moving the joystick down. If you push the joystick with CSP displayed, the value will revert to the standard value of 2 without affecting the WSP value.

If the character space differs from the standard value, the word speed will be lower than the character speed, and this difference is reflected in the speed display. A display of 15C10W means, e.g., that the character speed is equivalent to 15wpm, and the additional character and word spacing reduces the word speed to 10wpm.

Adjusting the Word Space

The CW Trainer lets you use words with a larger than regular word space for training purposes. The standard timing is explained in the “Morse Timing and Speed” chapter above. In this keyer the incremental word space and character space can be adjusted separately, however there are some dependencies between both values. The word space has a minimum of 4 ticks and a maximum of 99 ticks. The word space can not be decreased below a value that is 2 ticks longer than the character space.

Make sure you are in adjustment mode (no down arrow in position 5). Move the joystick up or down in the Home column until you see the speed row. Move the joystick left to get the **WSP** (Word Space) display, initially WSP 4. You can increase this value by moving the joystick up, and you can decrease it by moving the joystick down. If you push the joystick with WSP displayed, the word space will be set to 4, the character space to 2, and the DashPlus feature (see below)

will be turned off – in effect pushing the joystick with WSP displayed restores standard timing.

If the word space differs from the standard value, the word speed will be lower than the character speed, and this difference is reflected in the speed display. A display of 15C10W means, e.g., that the character speed is equivalent to 15wpm, and the additional character and word spacing reduces the word speed to 10wpm.

Adjusting the Morse Speed Range

The keyer's character speed is determined by the position of the speed potentiometer and two settings that define the speed range that the potentiometer covers. If the AUTO+ feature is enabled, the value of the message timer will also enter into the calculation of the current speed, as explained in the next topic.

Make sure you are in adjustment mode (no down arrow in position 5). Move the joystick up or down in the Home column until you see the speed row. Move the joystick right until you see the LOW value or the HI value of the speed potentiometer. You can adjust either value up or down using joystick movements – but, of course, the LOW value cannot exceed the HI value, and the HI value cannot drop below the LOW value. The extreme values for the speed in this keyer are 5wpm at the lower end, and 75wpm at the high end.

If you change the HI or LOW setting, the actual speed is normally changed, too, because it reflects the relative position of the potentiometer between the two boundary values.

The actual speed of the keyer is determined with digital precision in increments of 1wpm as shown in the display, and it is calculated by reading the potentiometer position many times per second. Occasionally you may find the potentiometer in a position that leads to flickering between two adjacent speed values, because the conversion of the analog potentiometer position to a digital value can fluctuate a bit between successive measurements. The actual speed would also jump around exactly as shown on the display, although this is may not be noticeable because 1wpm is a small change and the jump may happen between characters. To avoid this effect, however, you should move the potentiometer a bit until the display, and the actual speed, is stable.

Using AUTOplus to Automatically Increment the Morse Speed

The keyer's character speed is determined by the position of the speed potentiometer and the two settings that define the speed range that the potentiometer covers. In addition this keyer has a setting, AUTO+, that allows you to let the speed go up automatically over time as a message is being sent.

Make sure you are in adjustment mode (no down arrow in position 5). Move the joystick up or down in the Home column until you see the speed row. Move the joystick right until you see AUTO+. Move the joystick up or down to increase or decrease the value of AUTO+. It can have values from 0 to 9. **0 means that the AUTO+ feature is switched off.**

While a message is being sent the message timer is running. With an AUTO+ value other than 0, the character speed increases by 1wpm every x minutes, where x is the AUTO+ number. This way the actual speed will go up while the message is being sent, starting from a value that is determined by the speed potentiometer. This automatic speedup, however, will stop when the speed has reached the HI value for the speed potentiometer (see previous topic), and the speed will remain constant from then on. Thus, if you start e.g. with a character speed of 15wpm and have AUTO+ set to 3 and the HI value of the speed potentiometer is 25wpm, the actual speed will "creep up" until it reaches 25wpm after 30 minutes and then stay at 25 wpm.

The speed increase is determined by the message duration shown on the timer, not the actual time since the start of the message. If you temporarily stop a message with the [Enter] key, the timer stops running, and so will the speed increase. If you reset the timer to 0 with the [.] (decimal point) key, the speed will drop back to its initial value and start stepping up again.

When AUTO+ is stepping up the speed of an ongoing message, you may occasionally notice a slightly longer than normal word space. This is because the keyer reports the speed increase by AUTO+ to the PC during the next word space, and the transmission of that information extends the word space by a small amount. (This happens even if no PC is attached, because the information is sent to the serial port in either case).

The DASHplus Feature

The use of this feature should be carefully considered since it distorts Morse characters. If DASHplus is enabled, the duration of the sound in a dash, as explained in the “Morse Timing and Speed” chapter above, is increased from 3 ticks to 5 ticks, thus emphasizing the difference between dots and dashes.

This is similar to the “weighting” adjustment that some keyers have, and it results in Morse characters that do not conform to the standard definition. **When you are using your paddle to create characters, the dashes will not be stretched, and you will hear the standard timing for characters.**

Make sure you are in adjustment mode (no down arrow in position 5). Move the joystick up or down in the Home column until you see the speed row. Move the joystick left to get the DASH+ display. Make sure you are in adjustment mode (no down arrow in position 5). Move the joystick up (ON) or down (OFF) to enable or disable DASHplus. The internal keyer timing is readjusted using the PARIS standard word, so that the speed display is still correct.

Setting the Key Type

Make sure you are in adjustment mode (no down arrow in position 5). Move the joystick up or down in the Home column until you see the OPTION row. Move the joystick right until you see IAMB B (or IAMB A, BUG, or HAND). Move the joystick up or down to cycle through IAMB A, IAMB B, BUG, and HAND.

Iambic modes A and B are used with single-lever and dual-lever paddles, and for single-lever paddles you can select either one. They differ in the way the final element of a Morse character is generated after you have squeezed both paddles together and then release them both. Typically this is a matter of personal preference determined by the mode you used when you initially started out with “squeeze” keys. Mode B, which was introduced later and requires more logic in a keyer, is a little more tolerant when you make subtle timing mistakes.

The BUG choice allows you to use a dual lever paddle to simulate a mechanical bug. The dots are generated automatically, but the dashes have to be formed manually. (Since the reverse function works for BUG, too, you even have a left-handed bug !)

The HAND choice allows you to use a straight key. The “hot” wire can be connected to either the tip or the ring of the stereo plug that goes into the CW

Machine device. If a dual- or single-lever paddle is connected, it will act as a **sideswiper (cootie)** key in HAND mode.

If keying is enabled (this is toggled with the NumLock key on the keypad), and you are activating a key, there is an up arrow in position 1 of the LCD that will flicker in sync with your signal. Toggling the Auto Character Space Feature (AUTOCS)

When this feature is enabled the space between two successive characters that you are sending with your key will always be at least the (standard) 3 ticks.

Make sure you are in adjustment mode (no down arrow in position 5). Move the joystick up or down until you see the OPTION row. Move the joystick right until you see AUTOCS. Move the joystick up (ON) or down (OFF) to enable or disable automatic character spacing.

Toggling the Auto Word Space Feature (AUTOWS)

When this feature is enabled the space between two successive words that you are sending with your key will always be at least the (standard) 7 ticks.

Make sure you are in adjustment mode (no down arrow in position 5). Move the joystick up or down until you see the OPTION row. Move the joystick right until you see AUTOWS. Move the joystick up (ON) or down (OFF) to enable or disable automatic word spacing.

Changing Volume and Pitch of the Sidetone (SOUND)

You can change the volume and the pitch of the keyer tone. The volume setting also controls the volume of the beep that is used to signal some events.

Make sure you are in adjustment mode (no down arrow in position 5). Move the joystick up or down until you see the OPTION row. Move the joystick right until you see SOUND. Move the joystick up or down to cycle through the VOL and PITCH options. With either one, moving the joystick up or down changes the volume or pitch and you'll briefly hear the new sound. When you are satisfied with the sound settings, push the joystick down, which will return you to SOUND.

Switching Keying On or Off (KEYING)

This setting controls the keyer output to key a transmitter. Since the CW Trainer is primarily a training device, keying is initially turned off, and you have to turn it on if you want to use it as a “regular” keyer attached to a transmitter. If this option is enabled, you can toggle the actual keying of the transmitter with the **NumLock** key on your keypad as described further below. Switching keying to on also switches the tone off; you can, however, switch the tone on as described in the next section.

Make sure you are in adjustment mode (no down arrow in position 5). Move the joystick up or down until you see the OPTION row. Move the joystick left until you see KEYING. Move the joystick up (ON) or down (OFF) to enable or disable the keying.

Switching the Tone On or Off (TONE)

This setting controls the generation of a sidetone for Morse signals when the transmitter is keyed - the tone is always on if you temporarily disable transmitter keying with the **NumLock** key. If you are using the CW Trainer as a “regular” keyer on the air, your transmitter will generate a sidetone and you probably want to switch the keyer tone off. (this is done automatically when you switch keying on) Switching the tone off will switch keying on – after all, you want some kind of output from the device ...

Make sure you are in adjustment mode (no down arrow in position 5). Move the joystick up or down until you see the OPTION row. Move the joystick right until you see TONE. Move the joystick up (ON) or down (OFF) to enable or disable the tone.

Setting the Key Orientation (REVRSE)

Make sure you are in adjustment mode (no down arrow in position 5). Move the joystick up or down until you see the OPTION row. Move the joystick left until you see REVRSE. Move the joystick up (ON) to reverse the paddle orientation, or down (OFF) to go back to “normal” orientation. Since there is no agreed standard how to wire a paddle, the terms normal and reverse have no special significance. Normally, if you are right handed, you would wire the paddle so that your thumb produces dots and your index finger dashes.

Setting the Serial Communication Speed

Initially the speed of the serial port is set to 38,400 baud, which can be sustained by most modern PC's. However, if you experience a loss of data or corrupted data in serial communication, you should try a slower speed. If you are using a terminal program it has to be adjusted to the same speed. Our ***CW Trainer Manager*** program will detect the speed automatically.

Make sure you are in adjustment mode (no down arrow in position 5). Move the joystick up or down in the Home column until you see the OPTION row. Move the joystick left until you see 38.4 K (or 19.2 K, or 9.6 K, or 4.8 K). Move the joystick up or down to select the communication speed.

Loading a Message File

The format of a message file is explained further below. Loading a message file erases **all** pre-existing messages in memory.

Make sure you are in adjustment mode (no down arrow in position 5) and **LOAD** is being displayed. If you don't see LOAD, use the up/down movement of the joystick in the Home column until you see it.

Moving the joystick left or right switches back to operational mode without changing anything.

Make sure that you have your terminal program running with the settings described in the "Serial Communication" section. To load your message file you push the joystick, and you'll see COMM (for communication) – the keyer is now waiting for a file from the PC, and you have about 30 seconds to get your terminal program to start the transmission. If you are using HyperTerminal, this is the "Send Textfile" option in the "Transfer" menu.

When the file has been received, you will see "O.K." on the LCD display, and any movement of the joystick put you into operational mode.

Resetting the Keyer

Pushing the reset button (a ***hardware reset***) of the keyer puts it into “deep sleep” with almost all functions disabled, and you can only wake it up by moving the joystick up. When it wakes up, however, the keyer firmware essentially resumes in the same state that it was in before. In other words, a hardware reset does not result in a ***firmware reset***.

Occasionally it may be necessary to reset the keyer and its internal variables to the default configuration settings, and there are two types of reset operation that you can initiate by pushing the joystick (like a button) while the version display scrolls across the screen after the keyer has been started. You can always get to the scrolling version display by pressing the (hardware) reset button on the keyer, and then moving the joystick up.

If you push the joystick briefly, you will see **RESET** on the screen, and then you are returned to the scrolling version display. This has reset the internal variables to their default settings. However, all messages that were loaded remain intact. If you keep the joystick pushed for more than 0.5 seconds while the version display scrolls across the screen, you will see **ERASE** followed by **RESET**. This erases all messages and then resets the internal variables. This full reset is done automatically every time a major new firmware version is loaded.

Using the CW Trainer

Using the CW Trainer is pretty straight forward. A main prerequisite is to load a suitable set of messages. These messages can then be played back by selecting a **lesson** (essentially a group of messages) and a message within a lesson by pressing the corresponding key on the numeric keypad.

Messages can have any content that suits your intended use. Our **CW Trainer Manager** program has features to create a great variety of training material including random character groups using selectable subsets of all characters, and messages containing random collections of words from a word list that you can specify. Messages could contain only a small subset of all characters that is expanded in later messages and lessons, probably following a proven approach like the Koch method. It is entirely up to you what constitutes a message and a lesson.

Using the adjustable Farnsworth timing and the automatic speed increment feature, you should be able to develop a training approach that lets you improve your copying and your sending skills regardless of your level of proficiency.

The Message File

A **message file** is a plain ASCII text file with imbedded “marks” to delineate message boundaries. These marks have the form **<nn>**, where nn is a two digit number designating the lesson and the message within a lesson. The marks precede the corresponding message. The first mark for message number 0 in lesson number 0, **<00>**, is implicitly added to the beginning of any text and should not be specified. Since the CW Trainer supports 10 lessons with 10 messages each, the marks range from **<01>** to **<99>**. The number in the angle brackets has to have **two digits** to be recognized. If a mark is specified several times, only the message following the last mark is accessible; any preceding message with the same mark will be stored in memory, but it cannot be accessed by any function.

Whenever a message file is loaded, all pre-existing messages, including orphaned messages that cannot be accessed as described above, are erased and replaced by the new messages. This implies that messages cannot be replaced or loaded individually, but only in a set of all messages.

Messages can contain any character. When a message is sent, lower case characters are converted to upper case, and characters that have no equivalent in Morse code are replaced by a word space.

If you are also using the CW Trainer as a memory keyer that is hooked up to your transmitter, you probably want to designate one “lesson”, i.e., a set of 10 messages, for the typical repetitive information during a QSO, like calling CQ or sending your name and your QTH.

National Language Characters

The CW Trainer supports many national Morse characters. These characters are decoded and shown on the LCD when you enter them with a paddle, and if you use them in a message that you have created with a keyboard that supports these characters, most of them will be transmitted correctly. The LCD does not show these characters faithfully, but an attempt has been made to at least make them unique and recognizable.

Ä (.-.-)	Ö (---.)	Ü (..--)	Ñ (---..)
Å (.-.-)	Ç (-.-..)	È (.-.-)	É (..-..)
Å (.-.-)	Æ (.-.-)	Ø (---.)	Ð (..-..)
þ (.-.-)			

If you look closely, you can see that these encodings are not unambiguous. Obviously **Ä** = **Æ**, **Å** = **Å**, and **Ö** = **Ø**. The CW Trainer always echoes the first (**ÄÅÖ**) to a terminal program. Our CW Trainer Manager lets you choose whether you want to display the German/French characters **ÄÅÖ** or the Nordic characters **ÆÅØ**.

The characters with a circumflex (^) are actually not encoded in a single byte, and you cannot store them in a message; but when you enter them with a paddle, they are echoed to the terminal program as the lower case character without the circumflex.

In addition the international character for **ch** (----) is supported. Since it does not have a single key on a keyboard, it has to be substituted in messages by another character that is not used in Morse code. The CW Trainer uses the * (asterisk) character for that purpose.

Operational Prosigns

The operational prosigns, usually represented as two characters that are sent as one, and their substitutes are:

- **=** : is <bt> -...-
- **>** : is <bk> -...-.-
- **+** : is <ar> .-.-.
- **(** : is <kn> -.-.
- **%** : is <ka> -.-.-
- **#** : is <sk> ...-.-
- **^** : is <ve> ...-.
- **&** : is <as> .-...

A consequence of this approach is, of course, that the operational prosigns are created whenever the corresponding character is encountered in “regular” text that you may have pasted from some source into a message – usually the prosign is not what was intended there, but there are no other encodings of these characters that would create a conflict.

Keypad Functions

The numeric keypad that is attached to the device can be either a separate numeric keypad, or the numeric keypad side of a full-size 101-keyboard. **If you are using a full-size keyboard, only the keys on the numeric keypad will invoke any function.** (The Windows keyboard of the CW Trainer Manager, however, lets you enter single characters that will be translated into Morse.)

Switching Keying and Tone On or Off [NumLock, Esc]

The NumLock key allows you to temporarily toggle the keying and tone functions. This toggle will only work if the **KEYING** option is enabled. When keying is enabled, there is an up-arrow in position 2 of the display, and another up-arrow in position 1 will flicker in sync with your signal. The CW Trainer may or may not generate a tone, depending on the setting of the **TONE** option. If you temporarily disable keying with the NumLock key you will always hear a tone, regardless of the setting of the **TONE** option. In other words: the **TONE** options controls whether the CW Trainer generates a tone when the transmitter is keyed. Normally your transmitter will generate a sidetone, and you would not want the CW Trainer to make a tone in that case. (For compatibility with the CW Trainer Manager software, you can also use the Esc for this function if you are using a keyboard.)

When you use the NumLock key the setting is not stored in permanent memory, unlike the corresponding settings for **TONE** and **KEYING** that you have in the menu system. If power is lost, the settings will revert to the status that was set in the menu system.

Changing the Lesson [/] or <do> Pseudo Prosign

When you press the “/” (forward slash, division) key on the numeric keypad, it has to be followed by one of the numeric keys (0 ... 9) on the keypad, which defines the **lesson** or group of messages that you are using. If the forward slash is not followed by a numeric key, the keyer will beep and the entry is ignored. Initially lesson 0 will be selected as a default; but once you have selected a lesson that setting is memorized, and all messages that you start with the number keys (see below) are part of that lesson.

In situations where you don't have a keypad, you can also change the lesson by entering the pseudo-prosign <do> (-..--- as one character) followed by the lesson number with your paddle. The keyer will beep to confirm the command.

Starting a Message [0 ... 9]

Pressing a number key on the numeric keypad starts the corresponding message. You should have previously selected a lesson as described above. If you haven't previously selected a lesson, lesson number 0 will be used. Whenever a message is started the timer will start counting from 00:00:00.

Interrupting and Resuming a Message [Enter]

While a message is being sent, it can be interrupted by tapping either side of the paddle or by pressing any key on the keypad. You can resume the message at the point of interruption by pressing the **[Enter]** key on the numeric keypad or the keyboard. Depending on where the interruption exactly occurred, the last character may be repeated when you resume.

Resetting the Timer [.]

When you press the "." (decimal point) key on the keypad, any ongoing message will stop, like it does for any key that you press on the keypad, but in addition the timer will be reset to 00:00:00. When you restart the message with [Enter] or [+], the timer will count up again.

Delayed Message Action [+] or <dm> Pseudo Prosign

When you press this key just before you start a message with one of the numeric keys, the actual start of the message will be delayed by about 3.5 seconds. This gives you time to grab pencil and paper and get ready before the message starts. You can also resume an interrupted message, like you do with the [Enter] key, and again, a 3.5 second delay will precede the first character.

In situations where you don't have a keypad, you can also start a message with a preceding delay by entering the pseudo-prosign <dm> (-.- as one character) followed by the message number with your paddle. The keyer will beep to confirm the command.

Backing Off by One Word [-]

When you press the “-“ (minus) key on the keypad, any ongoing message will stop, like it does for any key that you press on the keypad, but when you restart it with the [Enter] key as described above, it will resume one word before the last word that was sent. You can press the “-“ (minus) key several times to back off by several words all the way to the beginning of the current message.

Flash Card Mode [*]

Flash card mode lets you practice a skill that is essential for high-speed CW: copying complete words in your head. You toggle flash card mode with the “*” (multiplication) key on the numeric keypad, and when it is active you will also see an up arrow in position 5 of the LCD display.

When flash card mode is active and you are playing a message, a complete word will be sent but not be displayed character by character on the LCD or a connected PC while it is being sent. When the word space is reached there will be a 1.5 second delay, then the preceding word is shown for 2 seconds before this cycle is repeated for the next word in the message. Since the LCD shows only the last six characters, flash card mode is best used with a PC and our CW Trainer Manager program, which can fully show a longer word.

During flash card mode you can use your key to send the words that you hear. If you activate your key before a word has been flashed on the screen, the word that the Trainer sent will **not** be shown, and you would compare your whole transmission later to the message file that was used for flash card mode. If you activate your key after the word has been flashed on the screen, you can compare your transmission one word at a time. After your key has been “quiet” for more than 2 seconds, flash card mode will resume with the next word.

When you are using the CW Trainer as a memory keyer attached to your transmitter this obviously would not be a useful mode. Therefore, if you enable keying with the [NumLock] key or the menu setting, flash card mode will be switched off, and it cannot be toggled on while keying is enabled.

Appendix A: Error Codes

Some exceptional situations will create an error condition in the CW Machine. It will emit a beep and display an error code, ERR nn, where nn is a two-digit number. For these fatal errors, your only recourse is to press the hardware reset button. These are the error codes:

- 00 fatal.** Internal state error – you should never see this.
- 01 fatal.** Oscillator calibration error. The software calibrates the internal oscillator of the MPU to 8MHz +- 1% when the keyer is reset. There's little that can be done if this happens, except to try again. It may indicate a serious problem with your processor chip.
- 02 fatal.** EEPROM verification error. When the keyer is reset, parts of the internal EEPROM are formatted and verified. This error indicates an EEPROM failure. You can try again, but this probably indicates permanent damage to the processor chip.
- 03 fatal.** USART buffer overrun. The PC sent data faster than acceptable for the keyer and data was lost. Since the keyer uses the XON/XOFF protocol to pace data coming from the PC, in all probability your terminal program either didn't understand these signals, or they were lost in a poor cable connection. Make sure XON/XOFF is enabled in your terminal program and you are using a well-shielded cable.

Appendix B: The Menu Structure

The following pages show a pictorial representation of all menus and functions that you can navigate using the joystick.

The rectangular boxes represent a particular state that is shown on the display, the four lines leaving a rectangle correspond to the left – right – up – down movements of the joystick, and the circle on the rectangle represents the push-down action of the joystick.

CW Trainer Menu Structure

Operational Mode

- All functions are display-only, no adjustments can be made
- Up / Down joystick acts like left / right paddle
- Joystick push for less than 0.25 sec adjusts LCD contrast
- **Joystick push for more than 0.25 sec leaves operational mode and puts keyer into adjustment mode**
- Decoder display shows scrolling ticker tape.
- Timer display shows elapsed time since start of message or last timer reset

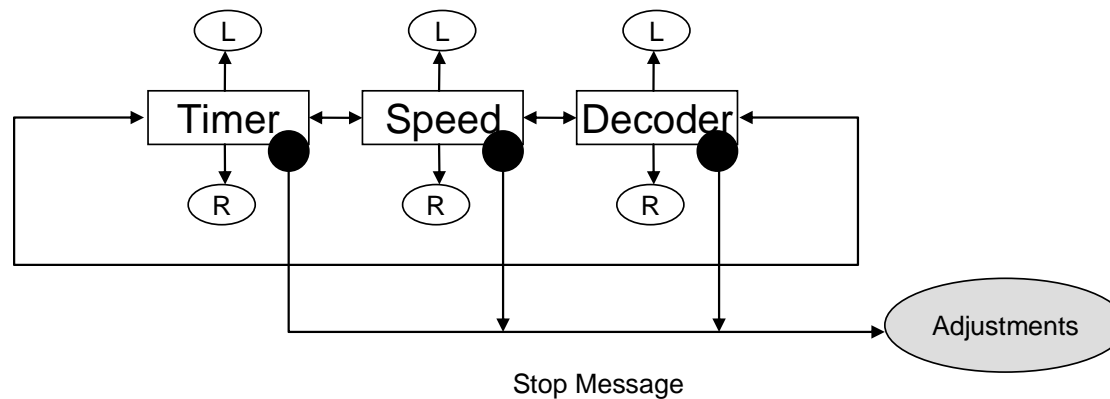

CW Trainer Menu Structure

Adjustment Mode

Keyer is returned to **operational mode** by pushing the joystick. On Speed and Option no other action takes place before operational mode is entered

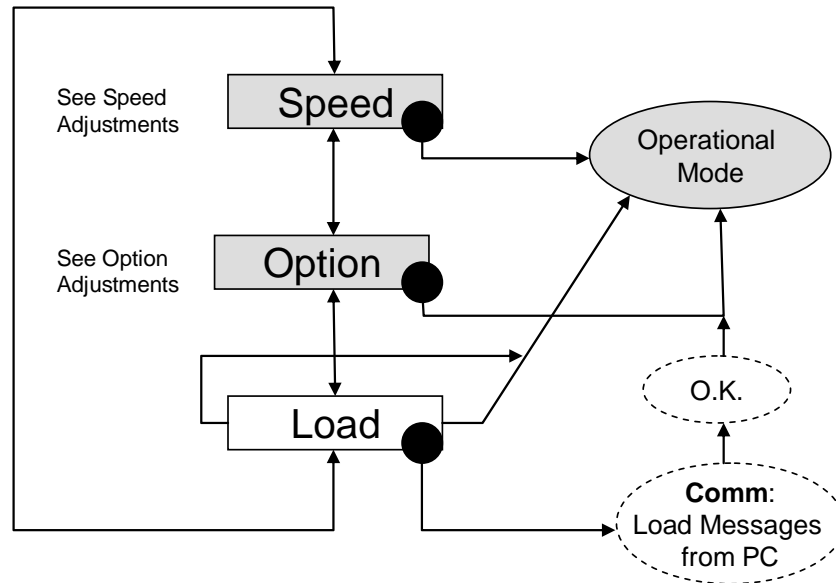

CW Trainer Menu Structure

Speed Adjustments

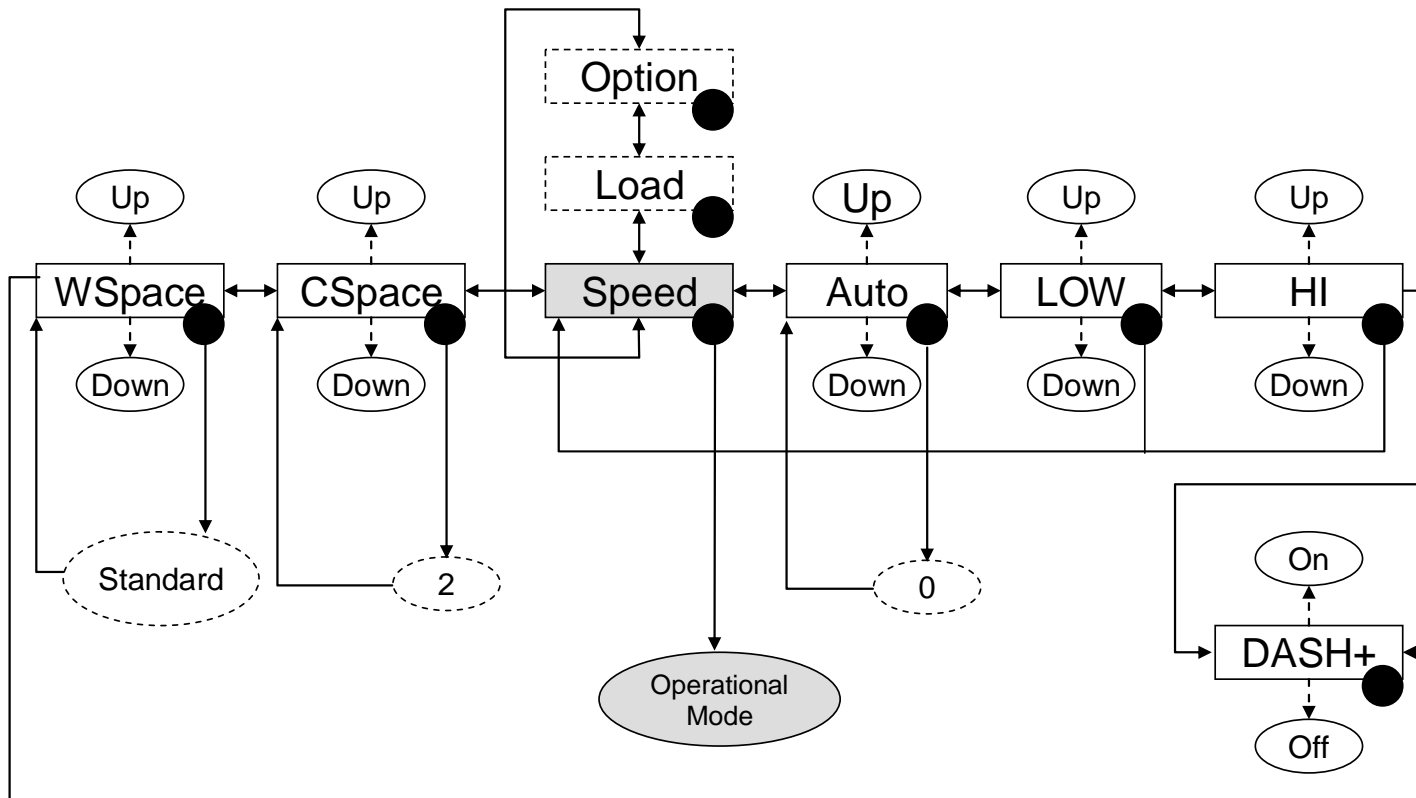

CW Trainer Menu Structure Option Adjustments

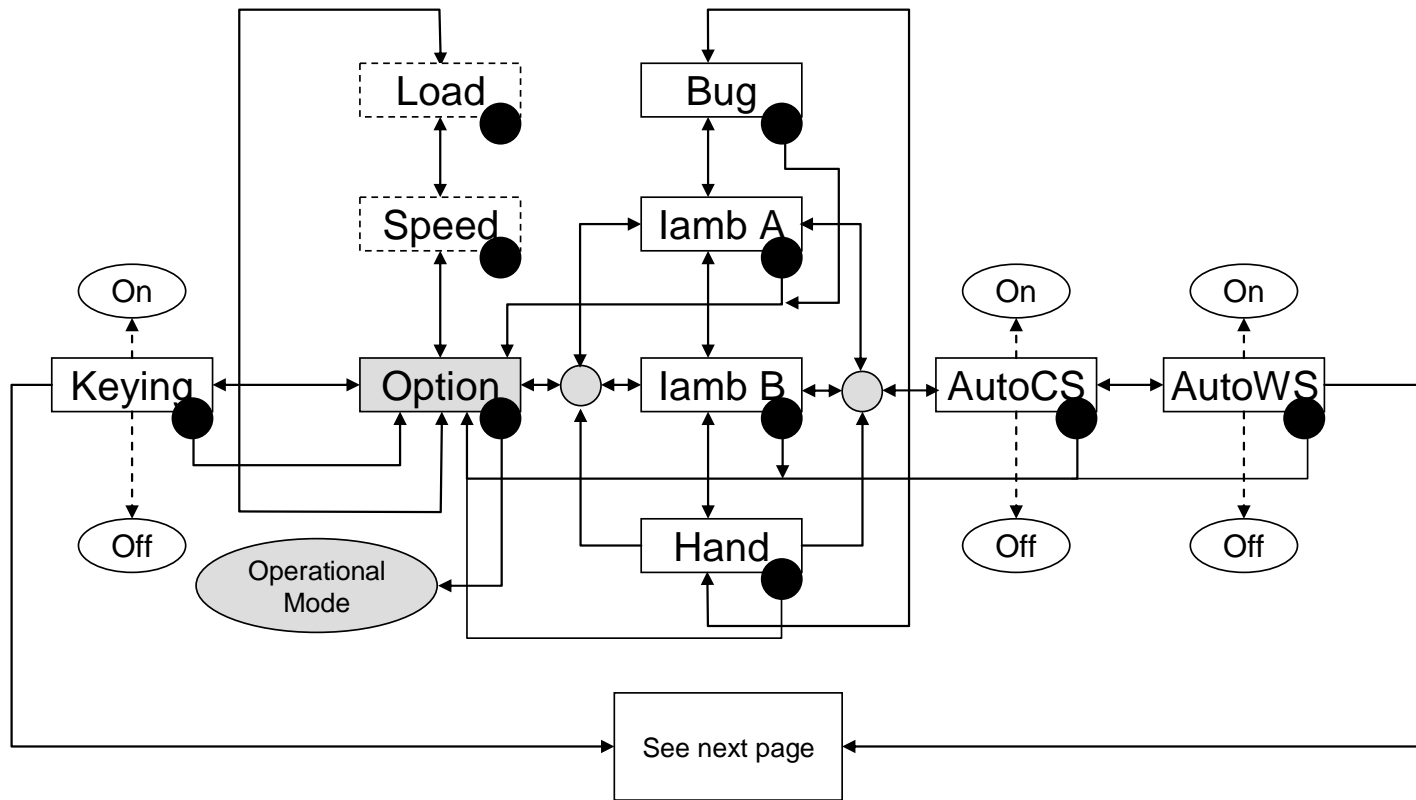

CW Trainer Menu Structure

Option Adjustments

